

Introduction to: DTI-tracking

AFNI Bootcamp (SSCC, NIMH, NIH)

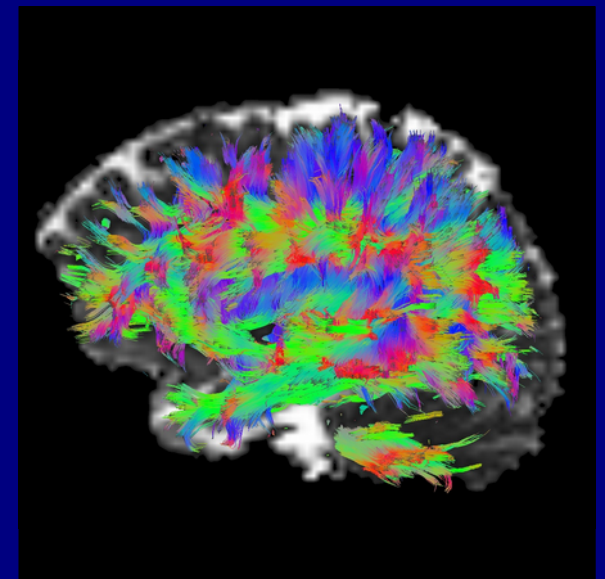

Outline

- + Using tractography (→ estimate extended structures)
 - motivation and goals of tracking
 - algorithms/properties
 - why GM+WM (→ function + structure)
 - thoughts on interpretation

NB: Online docs about FATCAT tools and processing:

https://afni.nimh.nih.gov/pub/dist/doc/html/doc/FATCAT/main_toc.html

https://afni.nimh.nih.gov/pub/dist/doc/html/doc/tutorials/fatcat_prep/main_toc.html

Structural connections in the brain

The (cartoon) structure of neurons

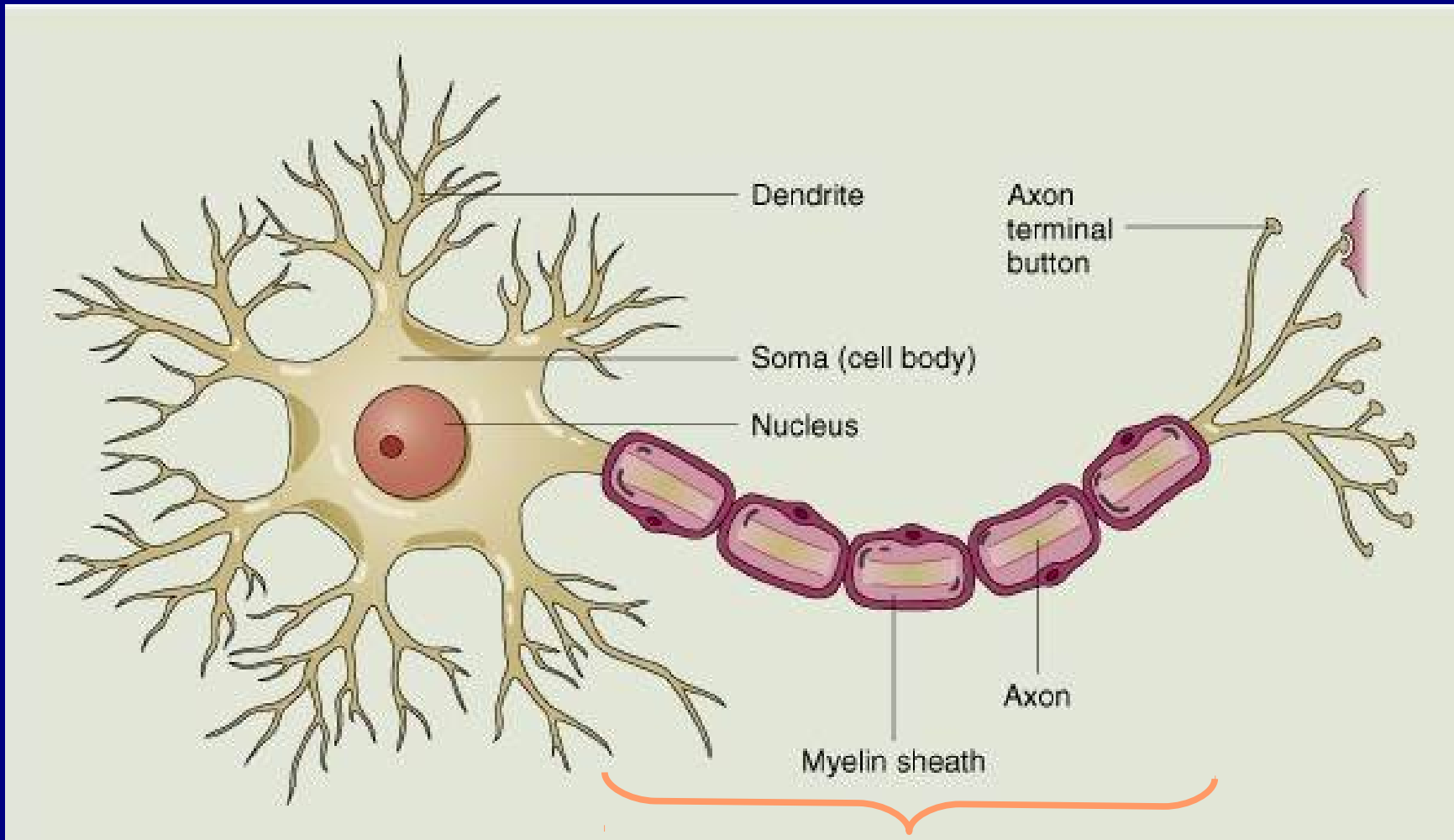

Extended white matter fibers,
often organized in bundles

Structural connections in the brain

The (cartoon) structure of neurons

Important fiber bundle scales, relative to DTI data

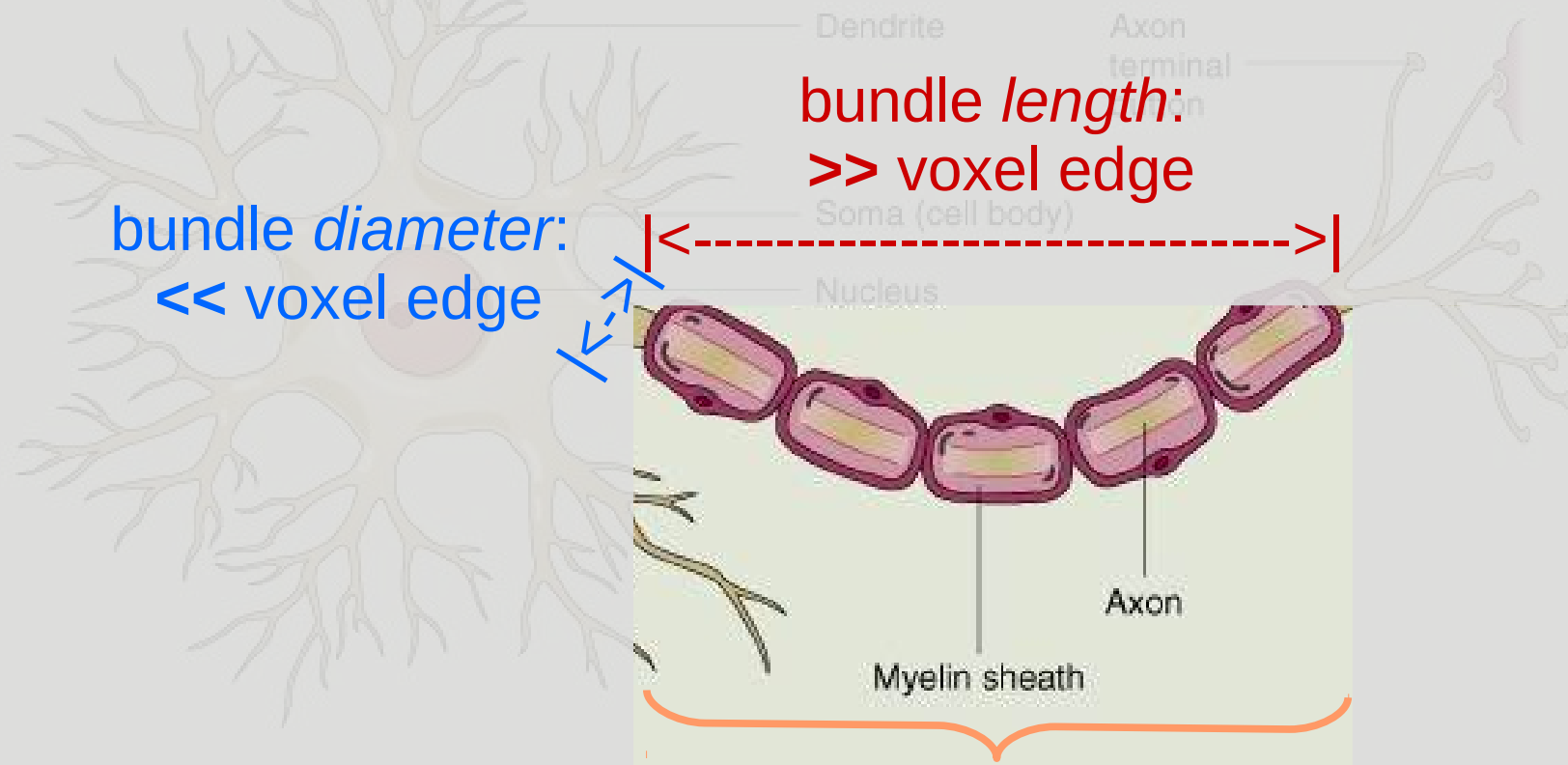

Extended white matter fibers,
often organized in bundles

How to use *local* structure information
to estimate *nonlocal* structures:
WM tractography

DTI: our information on WM structure

DTI-based parameters characterize some local structural properties and also show the presence of spatially-extended WM structures.

Can quantify local, structural (esp. WM) properties using:
FA, MD, RD, L1, etc.

Can investigate non-local or extended properties:
tractography

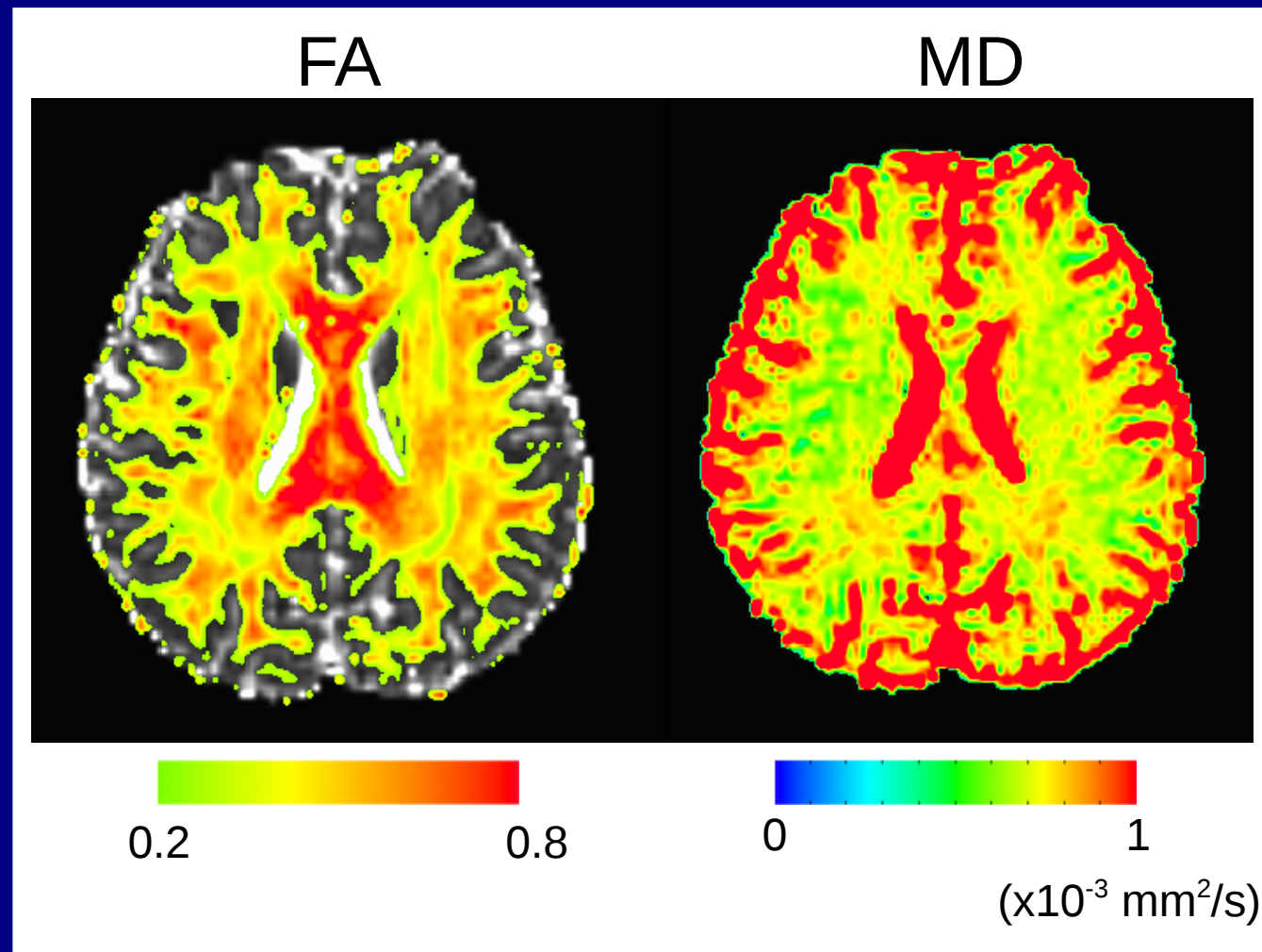

Tractography in brief

old, invasive



stain and preserve brain, get some
Idea of structure... non-ideal:
brain physiology changes postmortem,
also `mortem' aspect

new(er), theoretical

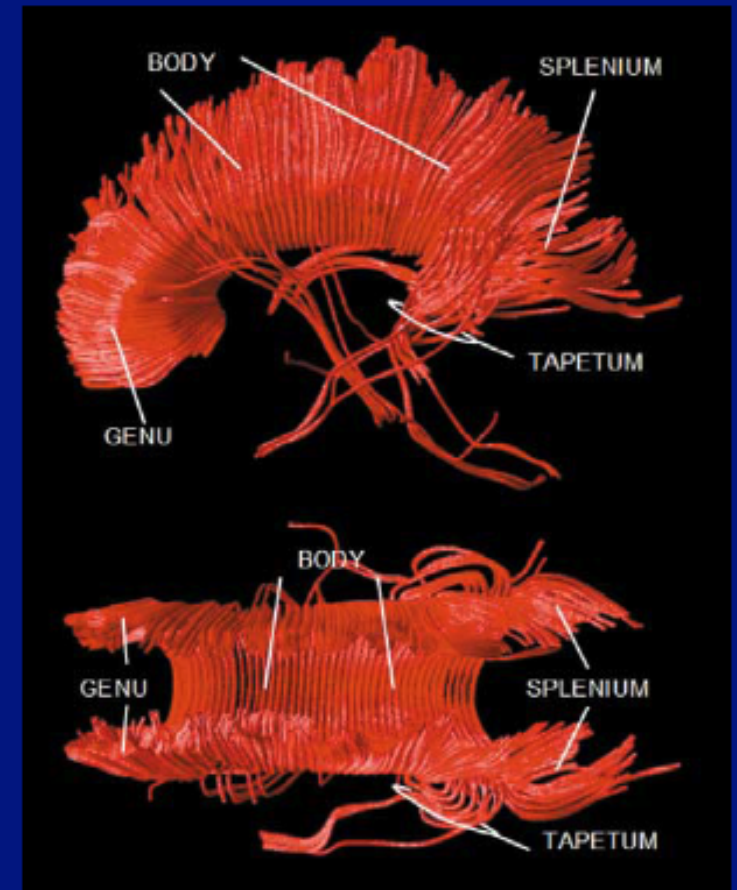

(images from Iowa Virtual Hospital
and Bammer et al. 2003)

Local DTs \rightarrow extended tracts

Field of local diffusion parameters

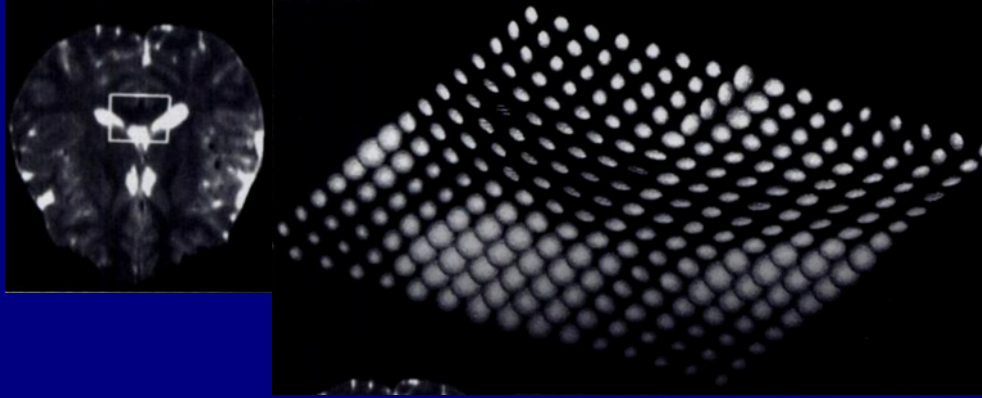

Local DTs \rightarrow extended tracts

Field of local diffusion parameters

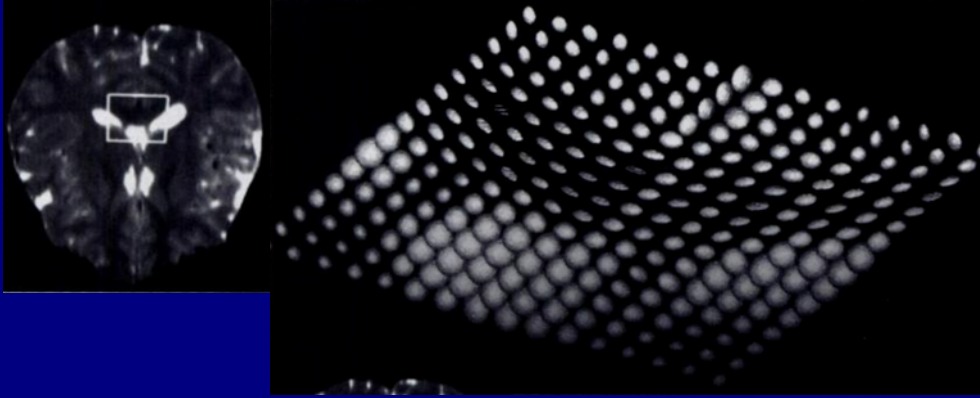

\rightarrow individual ellipsoids



Local DTs → extended tracts

Field of local diffusion parameters

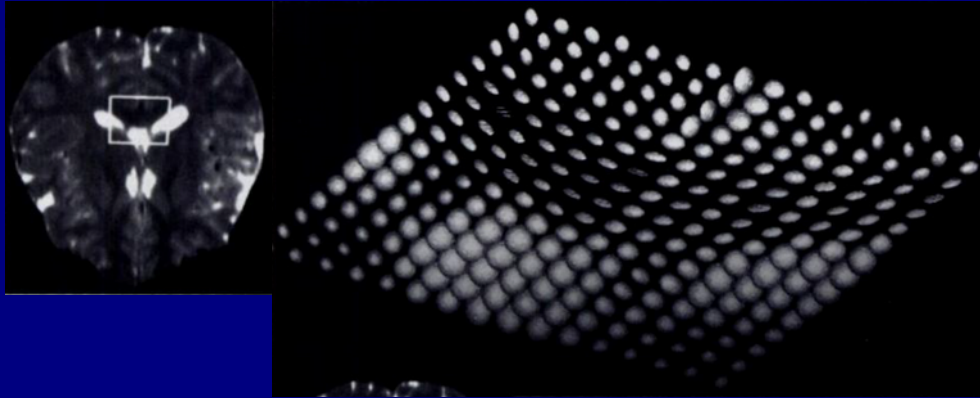

→ individual ellipsoids



Connect to form extended tracts

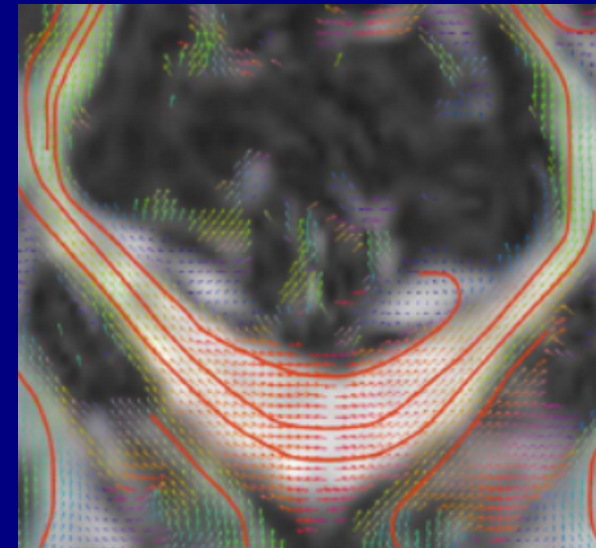

→ linked structures



Tractography: connecting the brain

(looking at you)

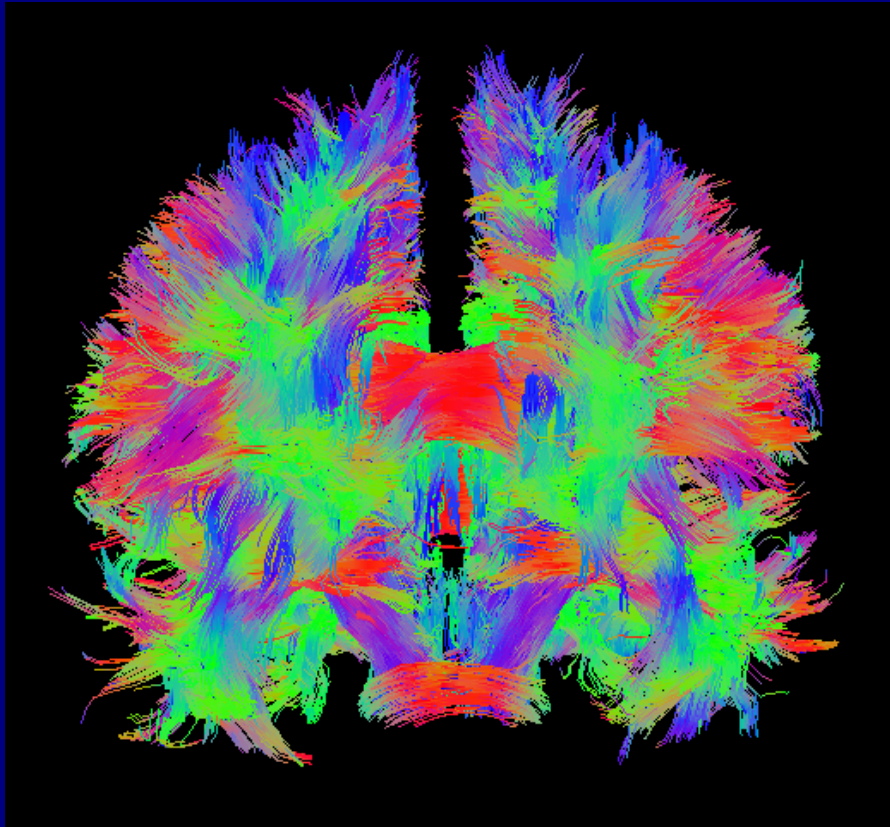

(looking downward)

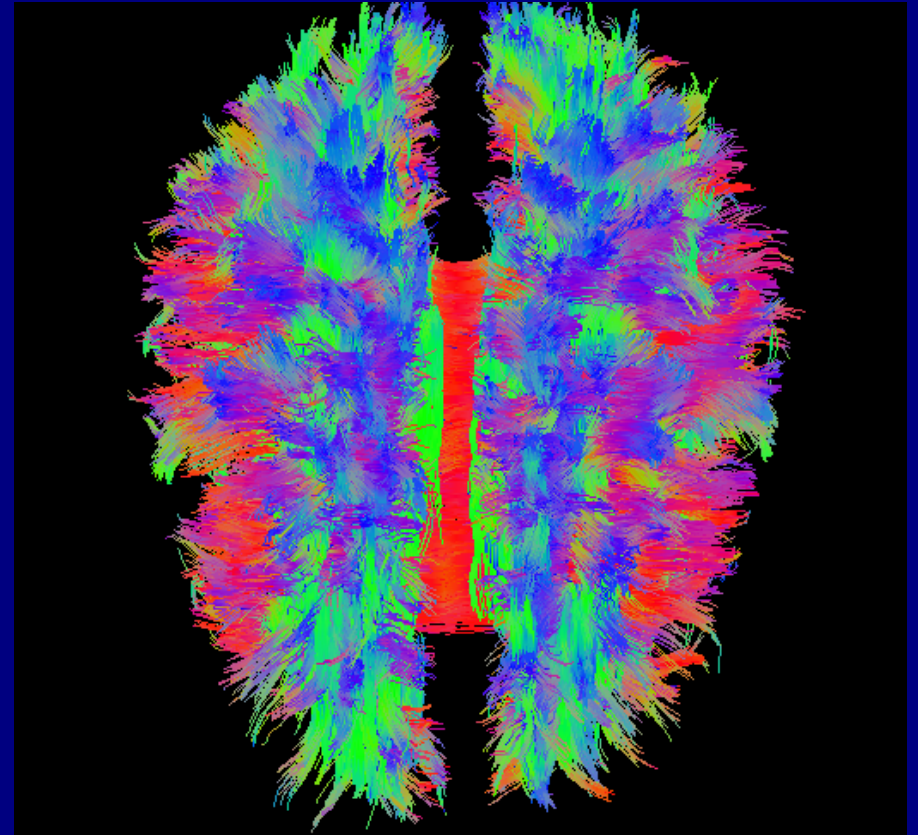

Tractography

Estimate WM structure (fiber tract locations)

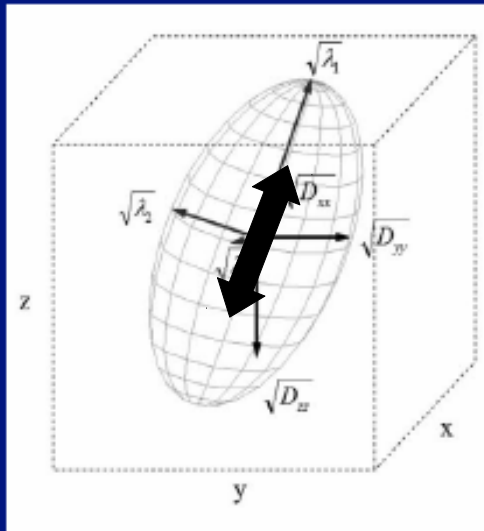

ellipsoid measures
(~smoothing of
real structures)

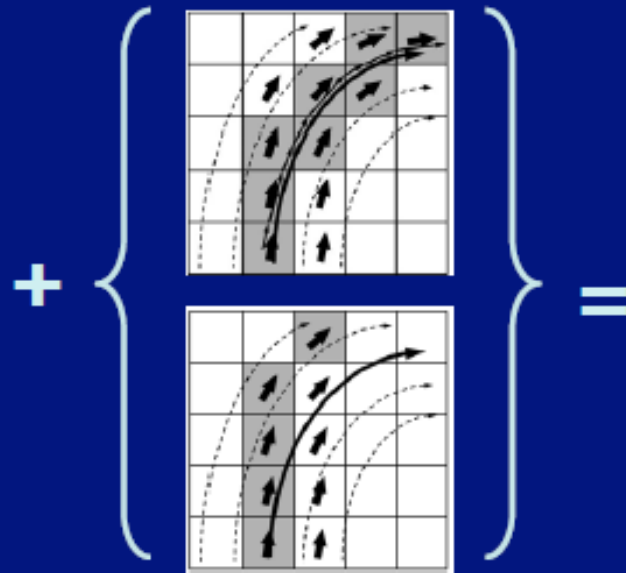

some kind of algorithm
for connecting

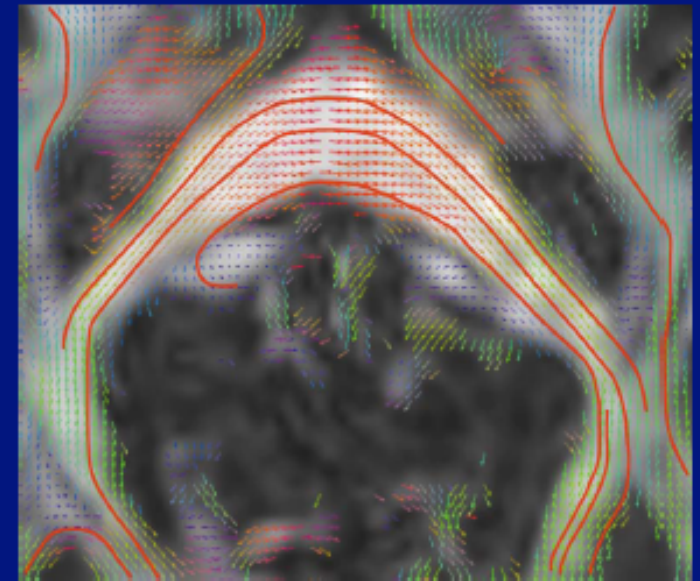

estimate spatial
extents of WM 'tracts'
in vivo

Diversity in tractography

Series of (mostly) logical, simple rules for estimating tracts

→ many methods/algorithms and kinds of parameters to choose:
(Mori et al., 1999; Conturo et al. 1999; Weinstein et al. 1999;
Basser et al. 2000; Poupon et al. 2001; Mangin et al. 2002;
Lazar et al. 2003; Taylor et al. 2012;)

Propagation via, e.g.:

smoothing diffusion vectors and solving differential equations;
deflecting propagating tracts; allowing tracts themselves to
'diffuse'; solving for global minimum energy of connections...

To date, no single 'best' algorithm, work continues:

- histology can't give perfect answers.
- some test models (phantoms) exist, but not brain-complex

So, first question for using tractography in a study:

Which algorithm to choose?

Popular technique: FACT

- FACT = Fiber Assessment by Continuous Tracking (Mori et al. 1999) [used more than 200 times in past 1.5 yrs]
 - Start in voxel with $FA > 0.2$ (proxy definition for WM)
 - Follow 1st eigenvector/greatest diffusion direction to next voxel
 - Continue if FA stays > 0.2 and angle between e_1 s is < 45 deg

Ex.:

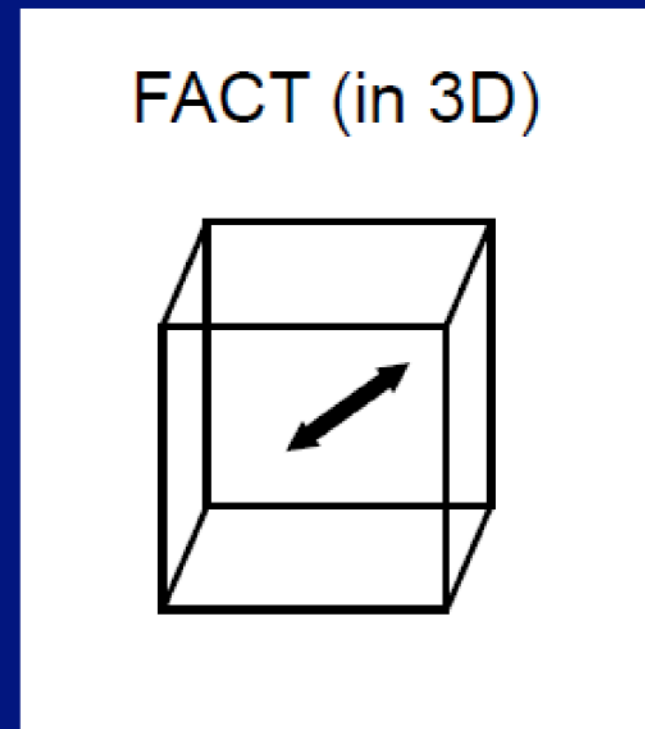
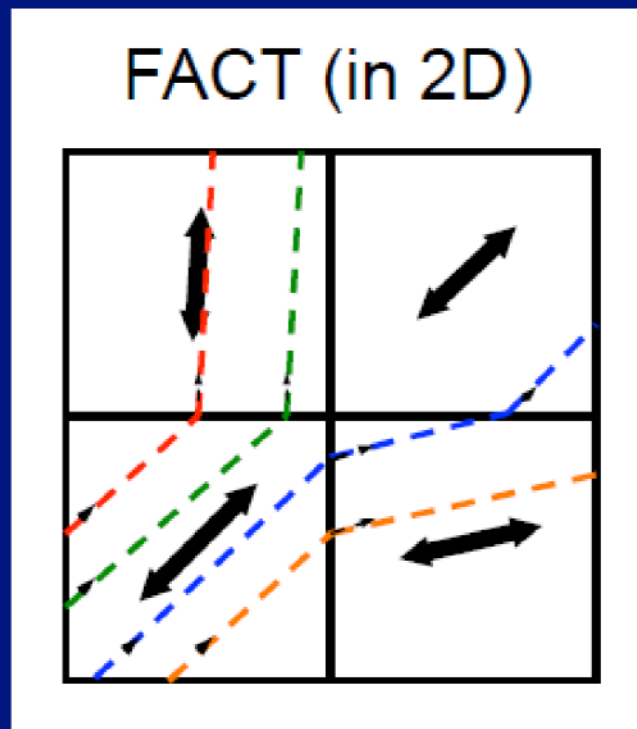

Very simple, but actually, gives some decent results, e.g. many known tracts

Popular technique: FACT

- FACT = Fiber Assessment by Continuous Tracking (Mori et al. 1999) [used more than 200 times in past 1.5 yrs]
 - Start in voxel with $FA > 0.2$ (proxy definition for WM)
 - Follow 1st eigenvector/greatest diffusion direction to next voxel
 - Continue if FA stays > 0.2 and angle between e_1 s is < 45 deg

Ex.:

FACT (in 2D)

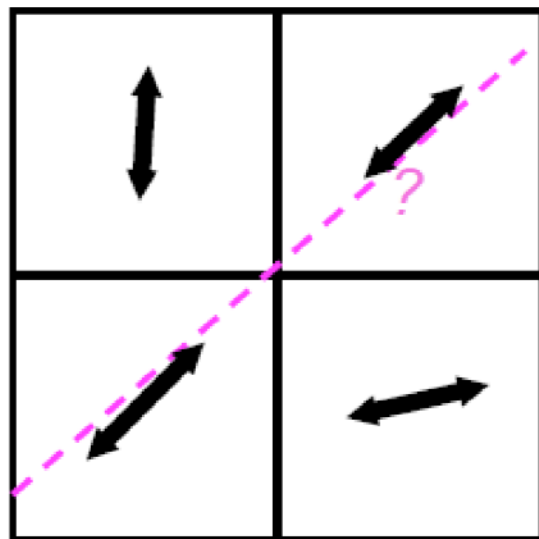

FACT (in 3D)

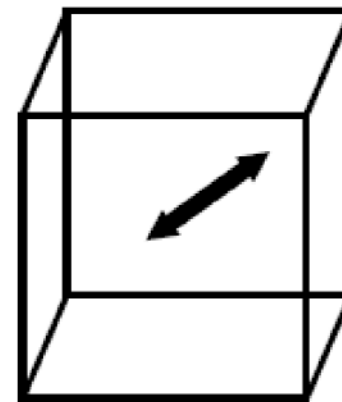

Very simple, but actually, gives some decent results, e.g. many known tracts **however... e.g. bias?*

Popular technique: FACT

- FACT = Fiber Assessment by Continuous Tracking (Mori et al. 1999) [used more than 200 times in past 1.5 yrs]
 - Start in voxel with $FA > 0.2$ (proxy definition for WM)
 - Follow 1st eigenvector/greatest diffusion direction to next voxel
 - Continue if $FA > 0.2$ and angle between e_1 s is < 45 deg

Ex.:

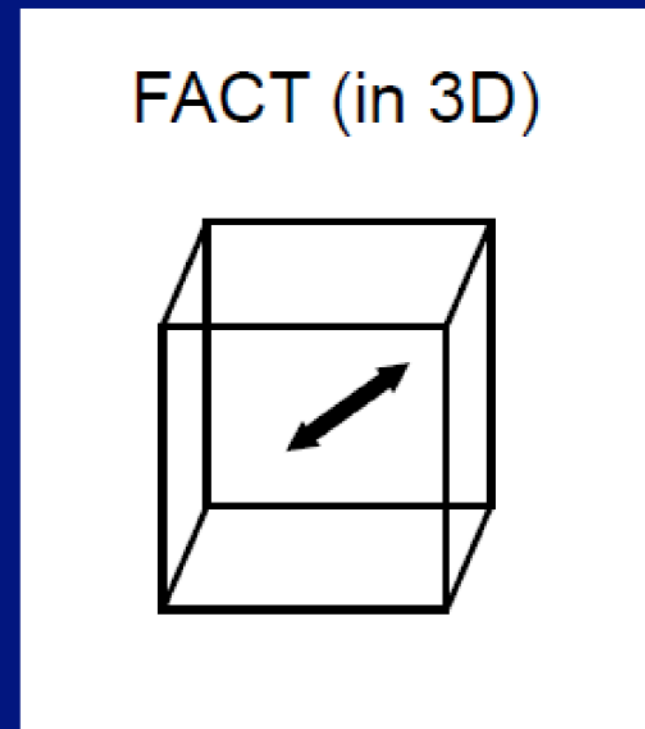
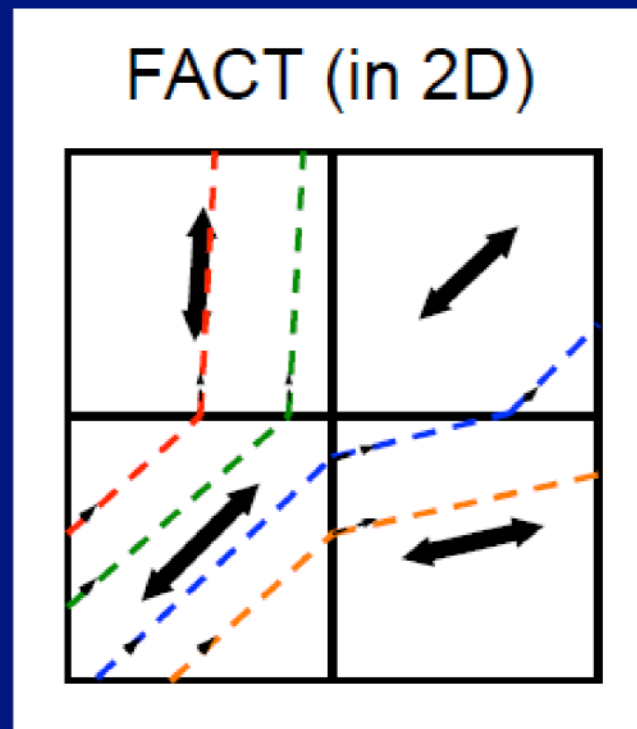

Very simple, but actually, gives some decent results, e.g. many known tracts **however... e.g. bias? noise dependence?*

Popular technique: FACT

- FACT = Fiber Assessment by Continuous Tracking (Mori et al. 1999) [used more than 200 times in past 1.5 yrs]
 - Start in voxel with $FA > 0.2$ (proxy definition for WM)
 - Follow 1st eigenvector/greatest diffusion direction to next voxel
 - Continue if $FA > 0.2$ and angle between e_1 s is < 45 deg

Ex.:

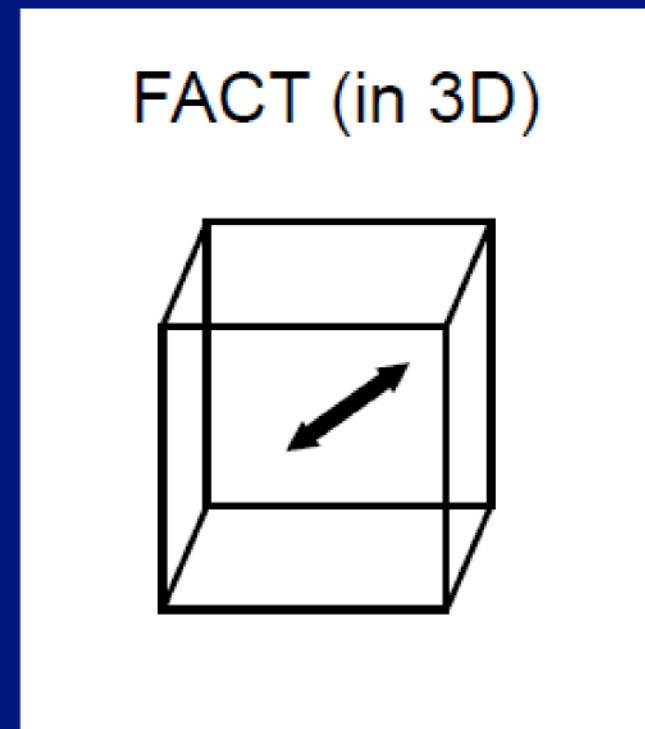
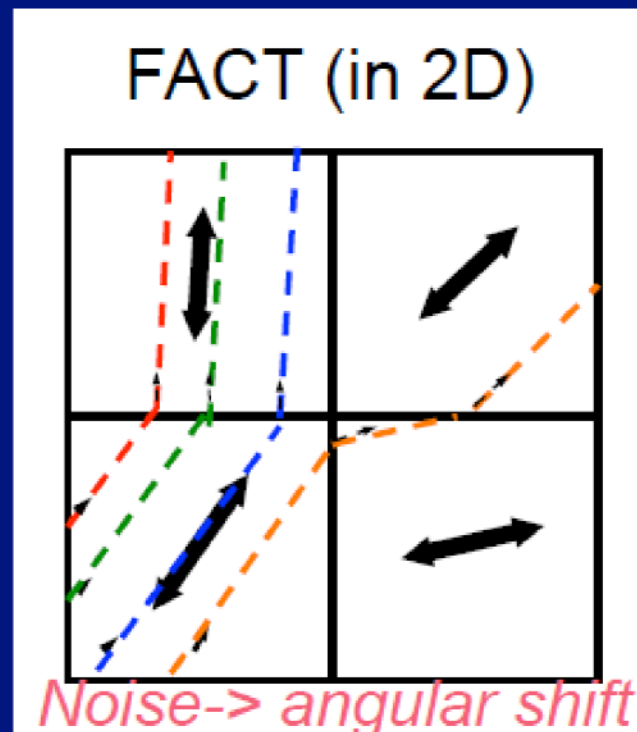

Very simple, but actually, gives some decent results, e.g. many known tracts
**however... e.g. bias? noise dependence?*

Improving FACT->

- Start by thinking: what properties a 'good' algorithm should have?
 - 1) Should be independent of coordinate axes (i.e., results invariant to rotation of data set)
 - 2) Should improve with spatial resolution (convergence in resolution)
e.g., like in calculus, diagonals are better approximated with small grid steps
 - 3) Should improve with SNR (converge in SNR)
 - 4) Should not have strong instability with or dependence on noise

Improving FACT->

- Start by thinking: what properties a 'good' algorithm should have?
 - 1) Should be independent of coordinate axes (i.e., results invariant to rotation of data set)
 - 2) Should improve with spatial resolution (convergence in resolution)
e.g., like in calculus, diagonals are better approximated with small grid steps
 - 3) Should improve with SNR (converge in SNR)
 - 4) Should not have strong instability with or dependence on noise

Posit: including diagonal (ID) propagation helps 1 and 4, check about other props.

FACTID (in 2D)

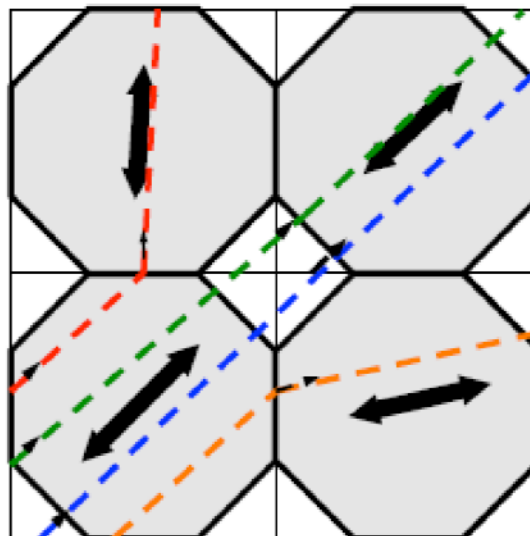

FACTID (in 3D)

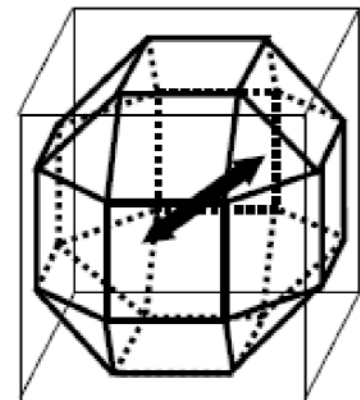

FACTID (FACT Including Diagonals):

+ Utilize simple check for diagonals.

(2D) Schematic:

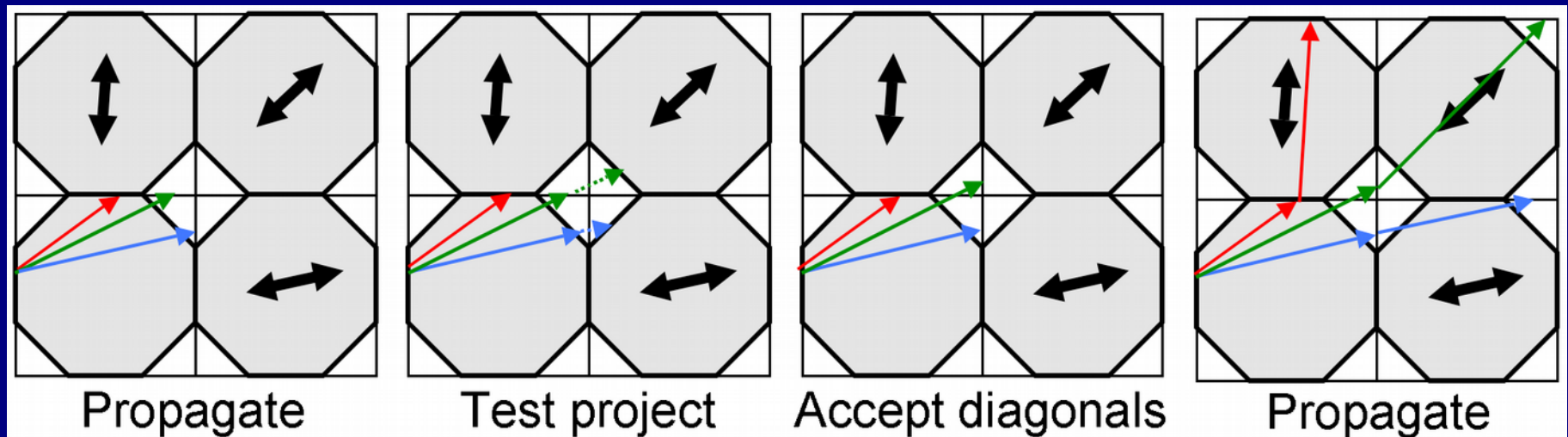

FACTID (FACT Including Diagonals):

+ Utilize simple check for diagonals.

(2D) Schematic:

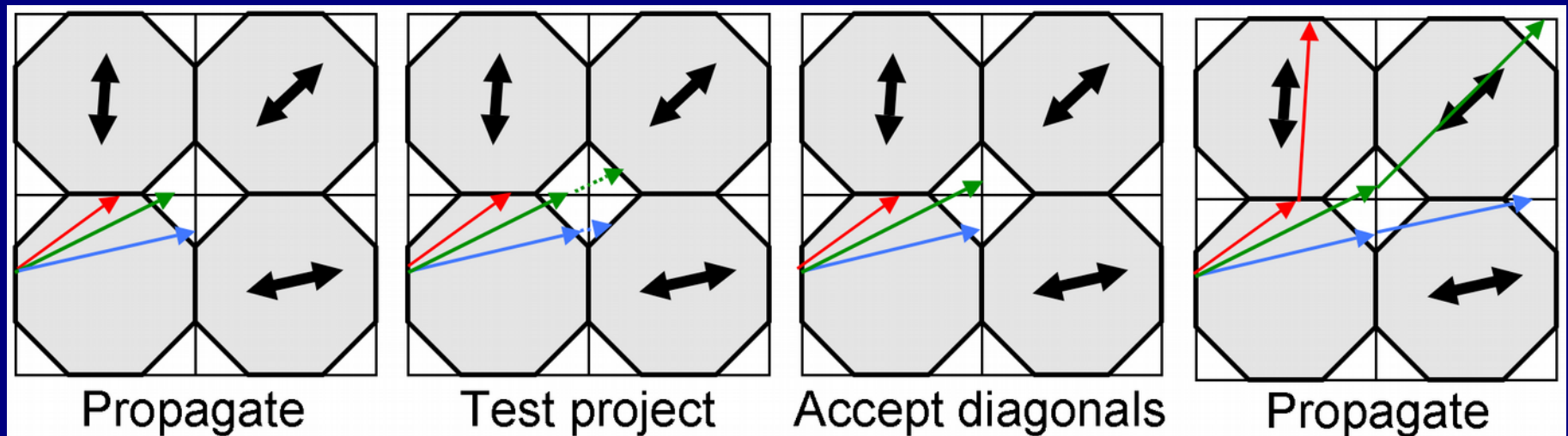

NB that in (3D) FACT, a single voxel has 6 neighbors for propagation, while in FACTID, a voxel has 26 neighbors propagation.

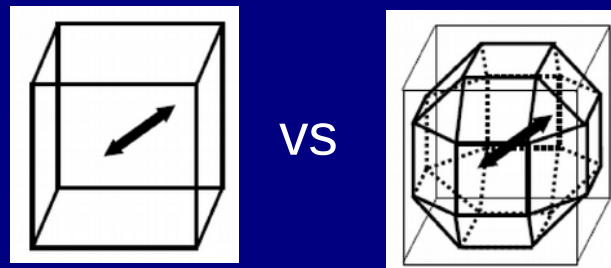

(Taylor, Cho, Lin & Biswal, 2012)

Test 1: Rotational invariance

A test for consistency of results when axes of data have been rotated; here, using data from a real subject (scan axes rotated)

FACTID



FACT



(Taylor, Cho, Lin & Biswal, 2012)

Test 3: Noise sensitivity

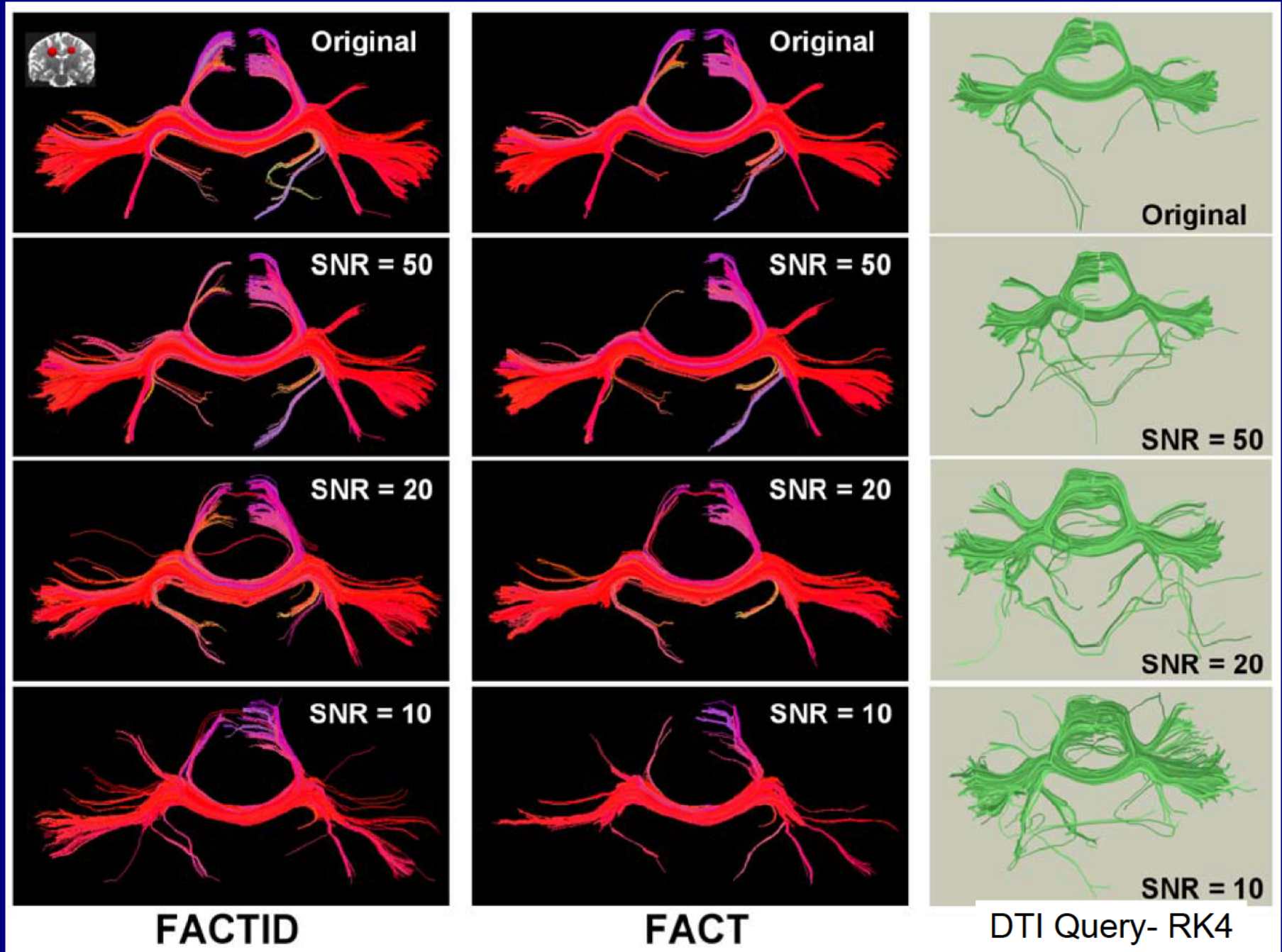

Test 5: Phantom Set

Fillard et al.
(2011, NI)
test phantom

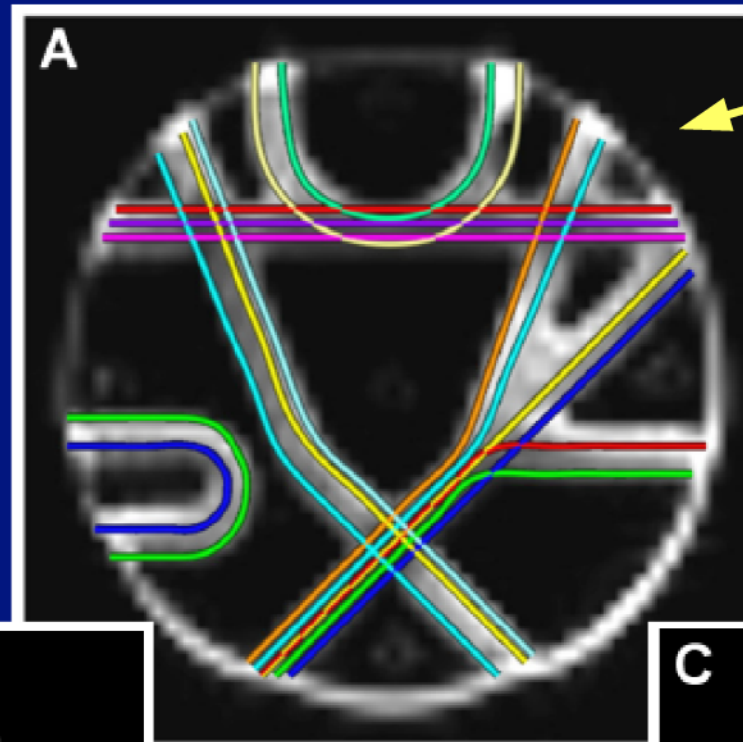

“ANSWER”

FACT

FACTID

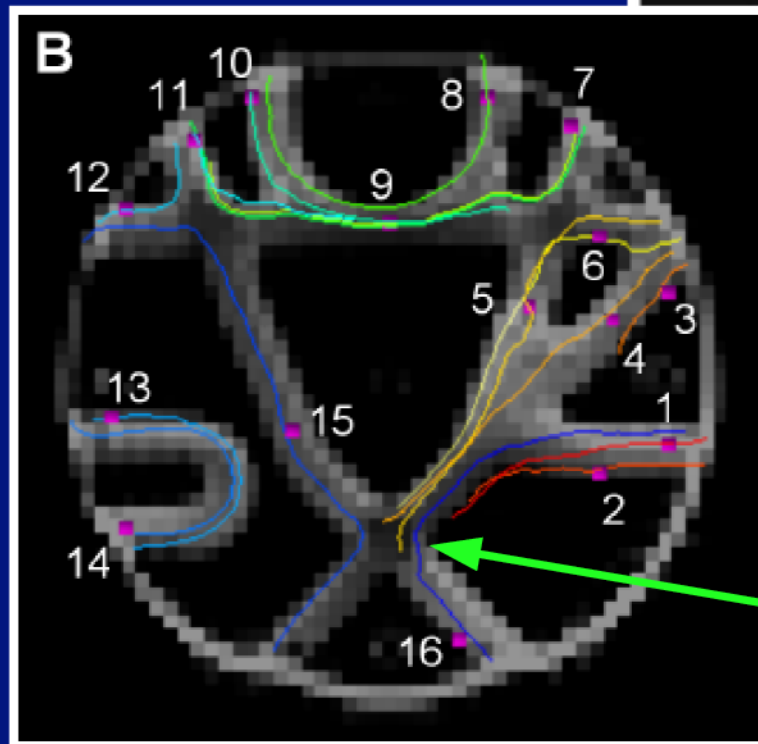

B

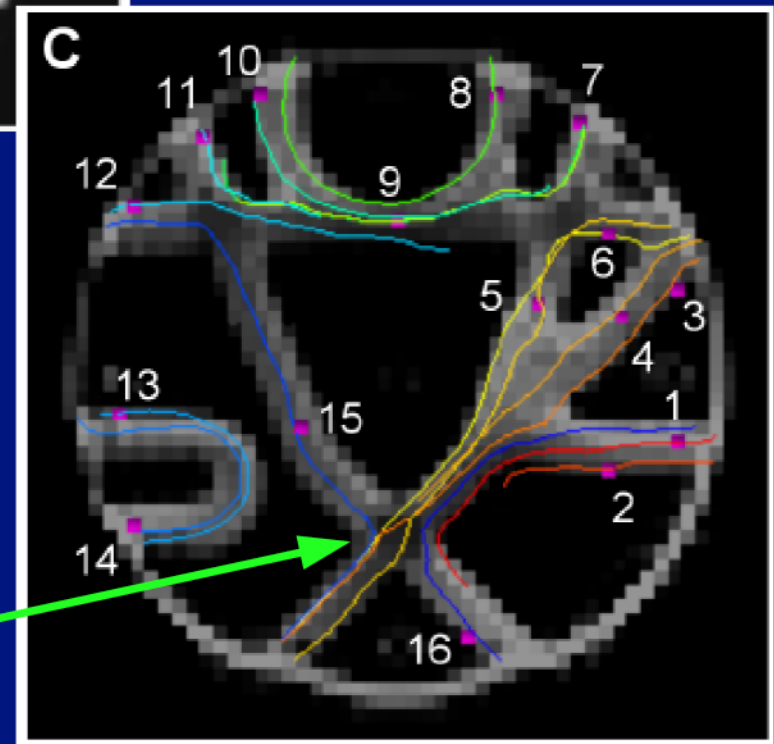

C

*(Taylor, Cho, Lin
& Biswal, 2012)*

e.g. compare

*In addition to tracking algorithms,
(great) care also has to be taken in
pre-processing the diffusion data.*

Importance of being processed (in earnest)

NB words of wisdom from wikipedia GIGO entry:

On two occasions I have been asked, "Pray, Mr. Babbage, if you put into the machine wrong figures, will the right answers come out?" ... I am not able rightly to apprehend the kind of confusion of ideas that could provoke such a question.

—Charles Babbage, [Passages from the Life of a Philosopher](#)

Importance of being processed (in earnest)

NB words of wisdom from wikipedia GIGO entry:

On two occasions I have been asked, "Pray, Mr. Babbage, if you put into the machine wrong figures, will the right answers come out?" ... I am not able rightly to apprehend the kind of confusion of ideas that could provoke such a question.

—Charles Babbage, [Passages from the Life of a Philosopher](#)

In addition to the tracking algorithm, the quality of data acquisition and preparation matter quite a bit

→ see the *TORTOISE* tool (Pierpaoli et al., 2010)

<https://science.nichd.nih.gov/confluence/display/nihpd/TORTOISE>

Importance of being processed (in earnest)

unprocessed

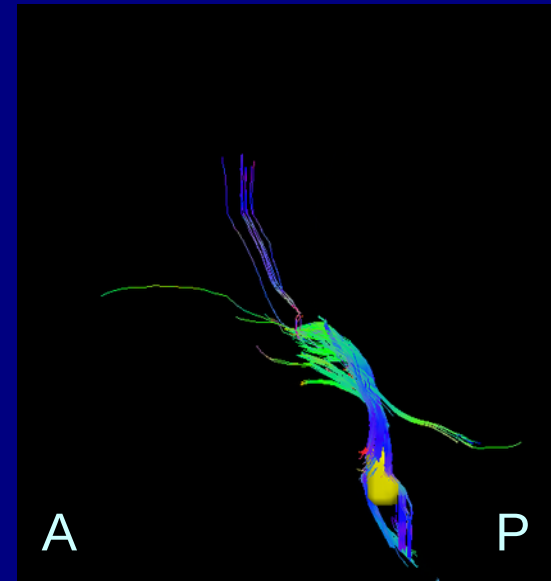
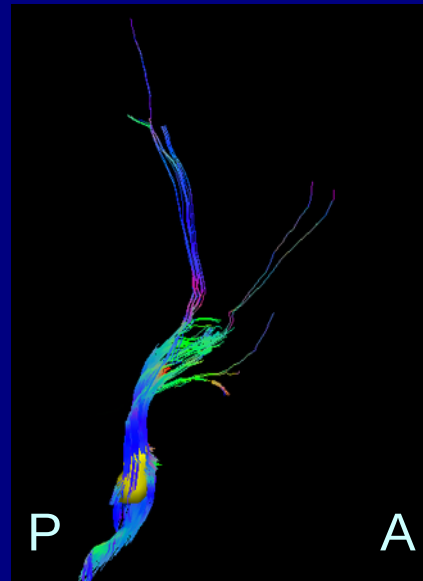
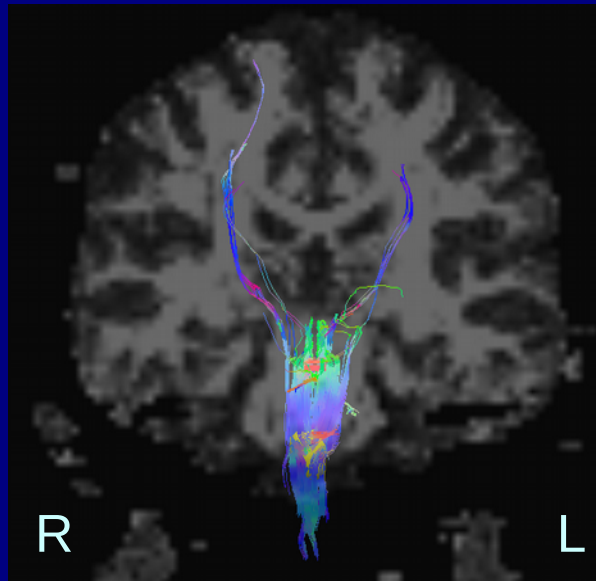

TORTOISED

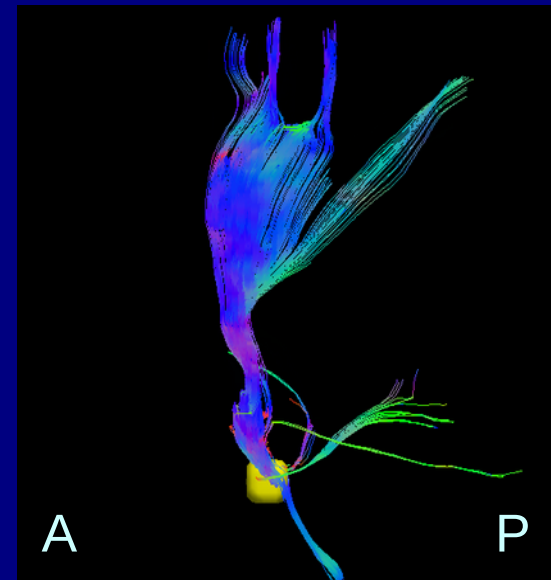
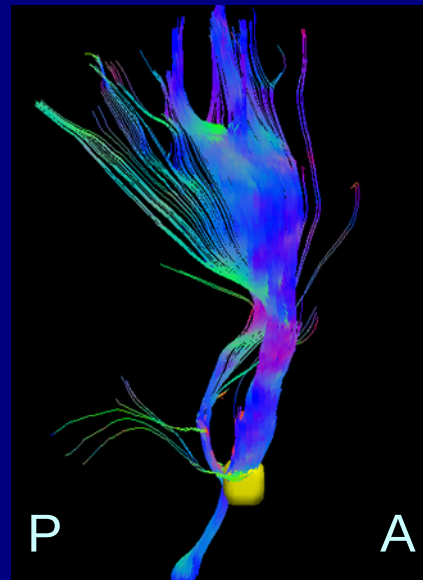
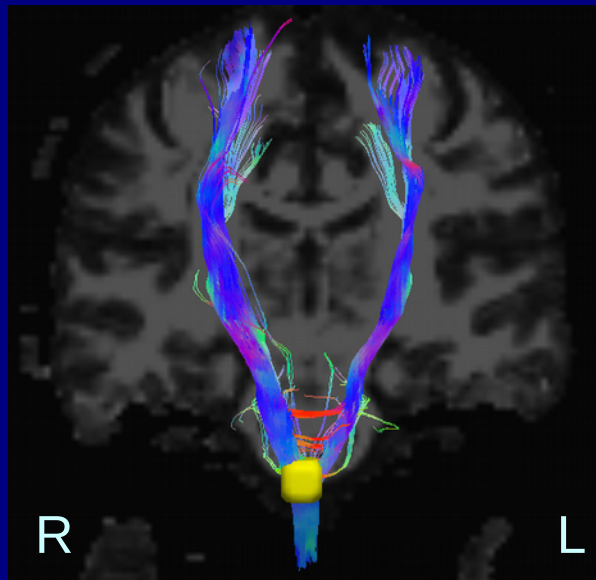

Data from the morning session, same target ROI in brainstem.
Consider reach of tracts, symmetry, physiology, etc.

How do we apply tractography?

Choice #1: what kinds of connections?

Case A: “Whole-brain (WB) tracking”

Track through whole WM mask
(e.g., where $FA > 0.2$)

- + Go to each “WM” voxel.
- + Track forward and backward from a starting point in each voxel (= “seed” point) until a stop criterion is reached.
- + Keep all tracts with length greater than some min (e.g., 20 mm).

Useful for quick QC of data.

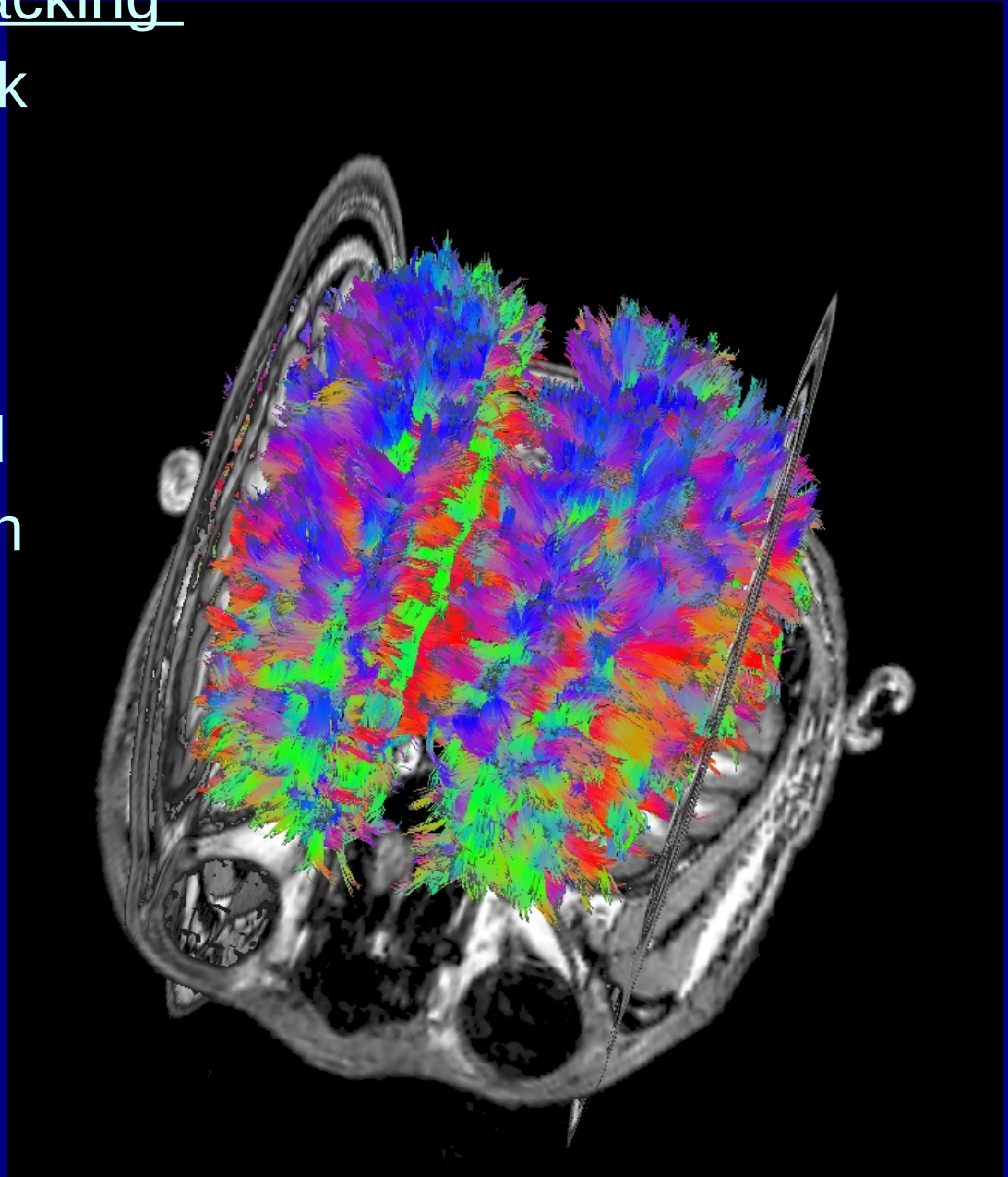

Choice #1: what kinds of connections?

Case B: ROIs + “OR-logic”

find and store all tracts in WB that go through *individual* “target” region(s)

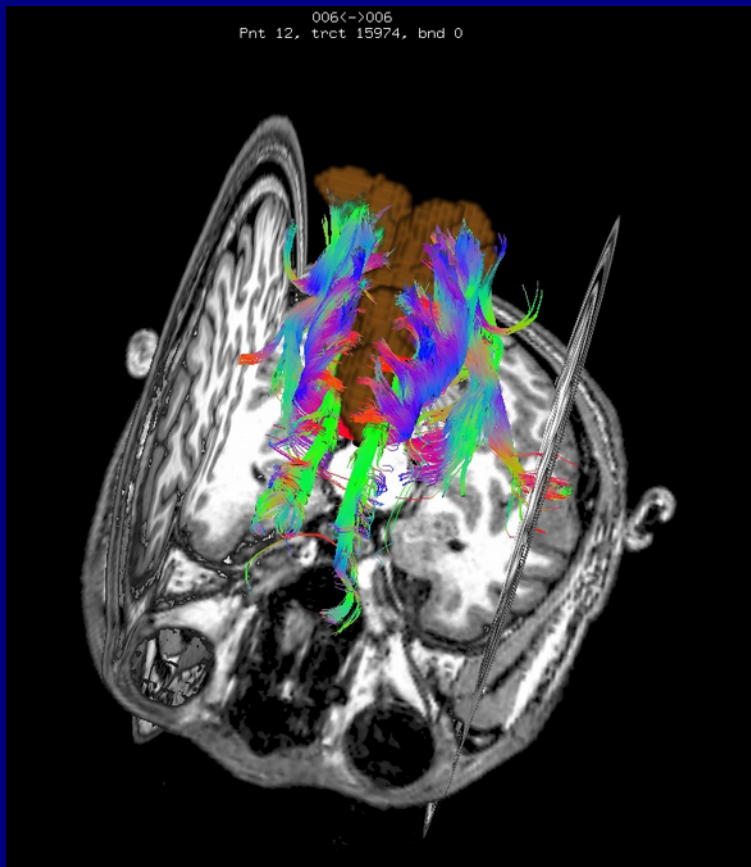

Case C: ROIs + “AND-logic”

find and store all tracts in WB that go through a *pair of* “target” regions

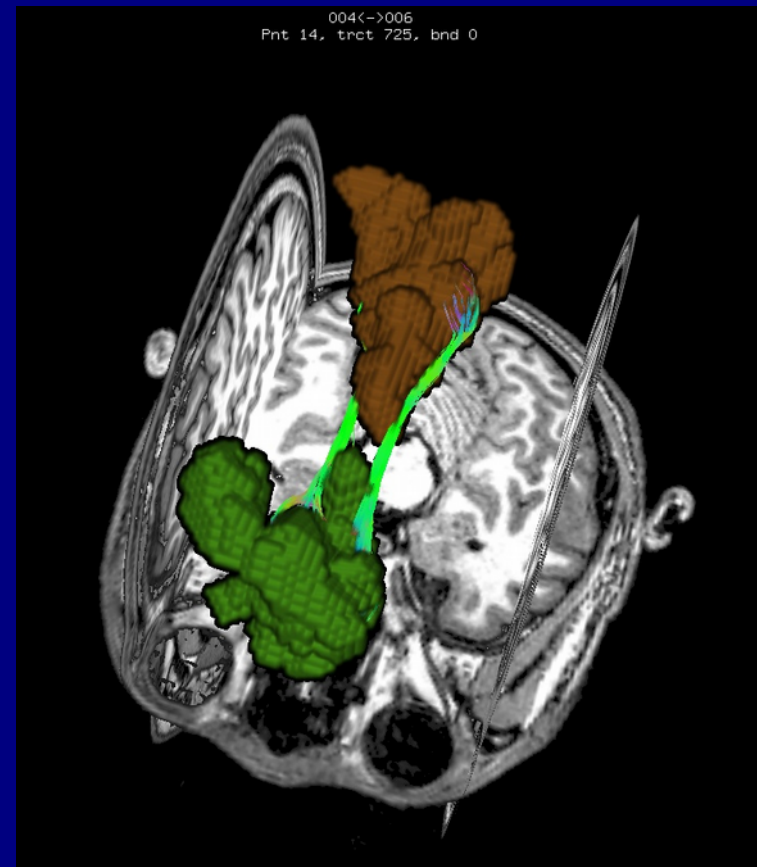

Choice #1: what kinds of connections?

Useful generalization of AND-logic:

“Network tracking”

through several target ROIs simultaneously. Find tracts in WB that go through any pair in a set of targets, where the targets make sense to think about together.

Note that the connections can be “sparse”: not every target is connected to every other target. (Physiologically, we would **not** expect otherwise...)

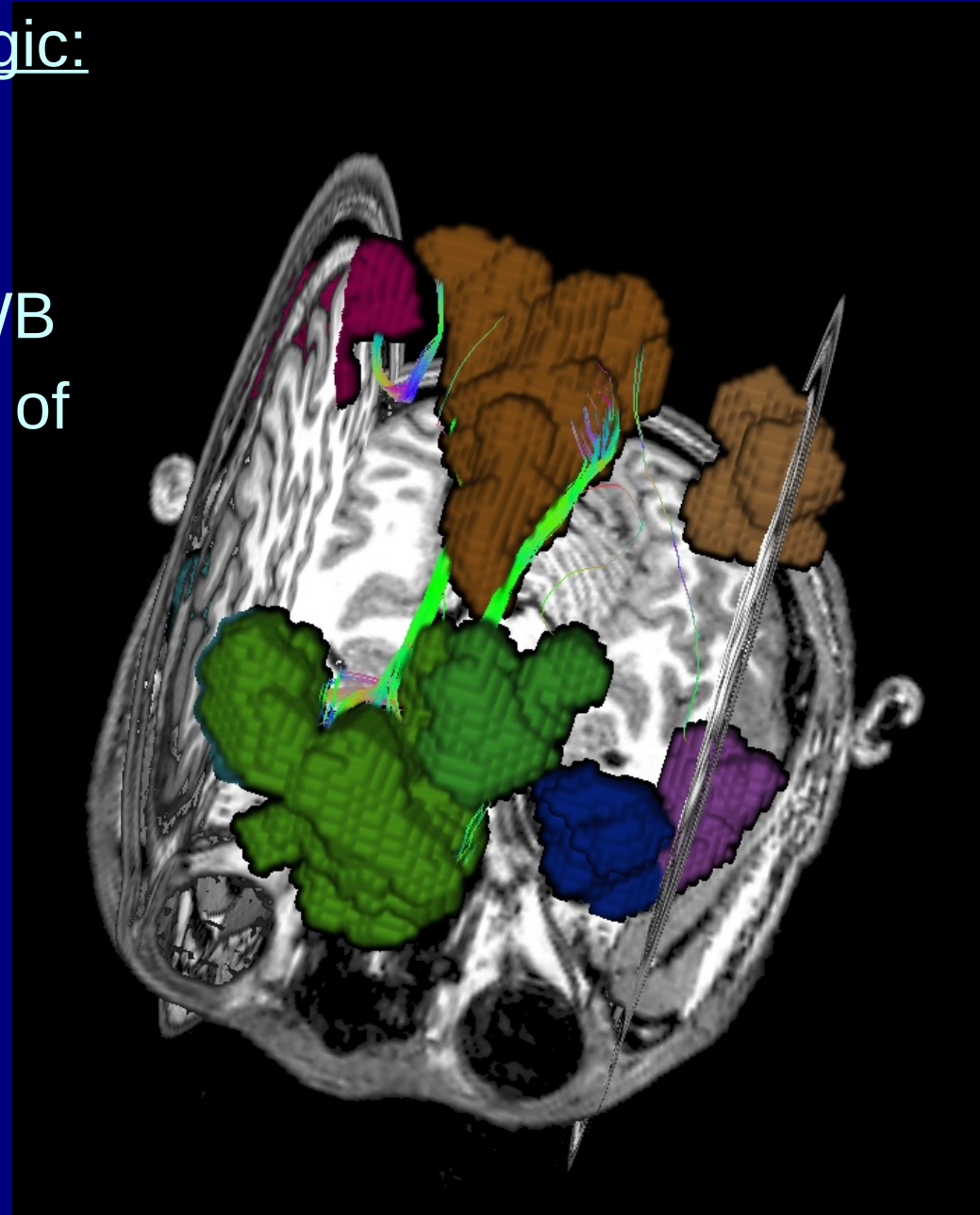

Choice #2: where to get targets?

Lots of choices! Some examples:

FMRI (e.g., thresholded seed-based or ICA maps)

Anatomical parc/seg (e.g., FreeSurfer)

Spheres/simple ROIs (can map across group)

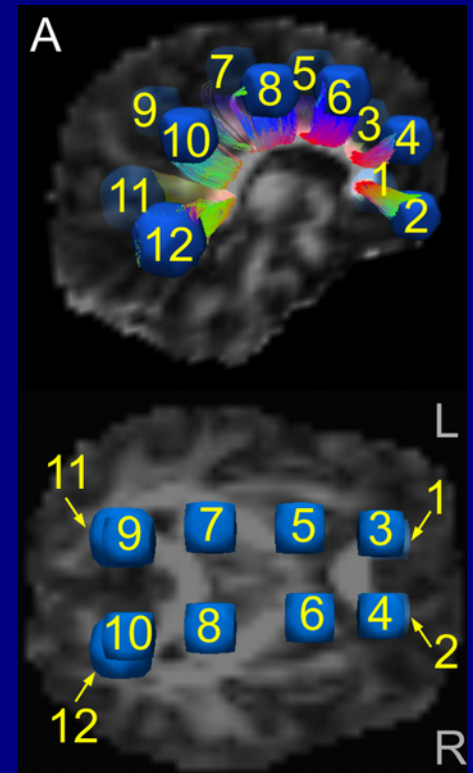
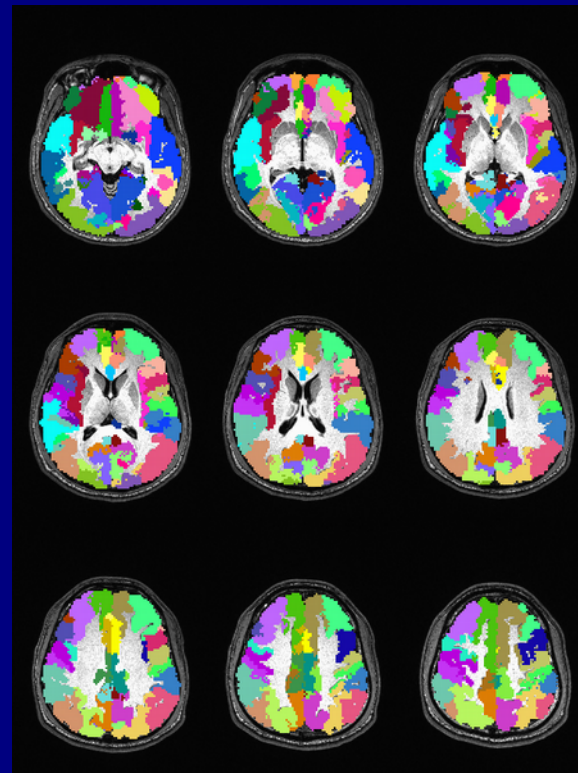
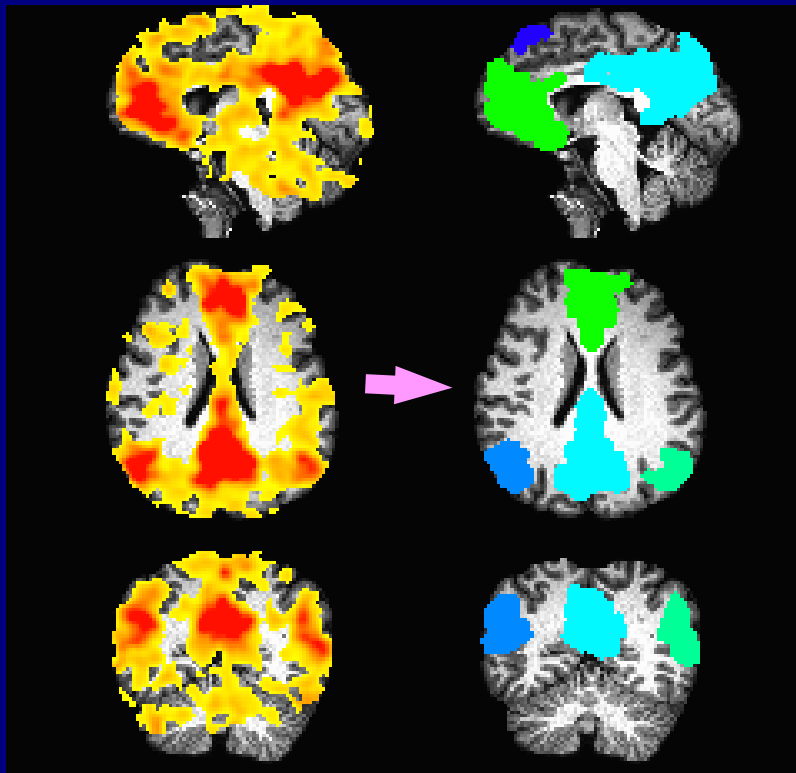

Terminology for tracking

Target: set of voxels (e.g., GM ROI) for which we want to find connections; in dset, target voxels have same integer value.

Network of targets: set of targets among which we want to find pairwise (AND-logic) or individual (OR-logic) connections (e.g., functional network).

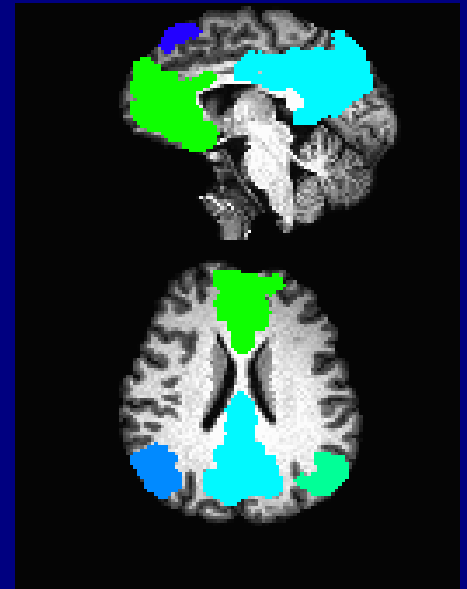

Terminology for tracking

Target: set of voxels (e.g., GM ROI) for which we want to find connections; in dset, target voxels have same integer value.

Network of targets: set of targets among which we want to find pairwise (AND-logic) or individual (OR-logic) connections (e.g., functional network).

Tract: set of ordered points in space related to estimated WM trajectory.

Bundle: set of one or more tracts through a single target (OR) or through any pair of targets (AND).

WMC “WM connection”: (or WM ROI) set of voxels through which a bundle passes; can calculate average quantities across WMC.

WM network: set of WMCs; for N targets, can store info on all possible connections $\rightarrow N \times N$ matrix.

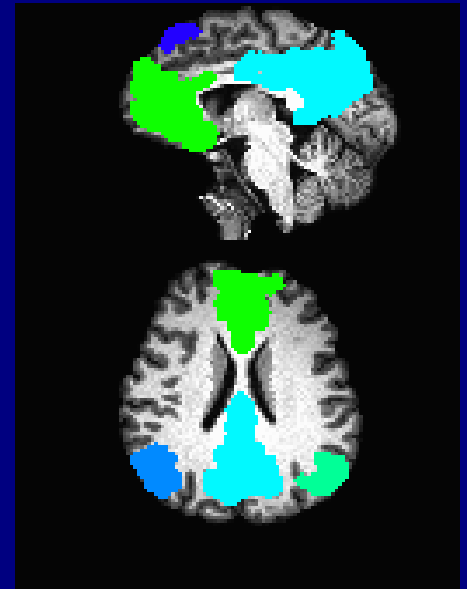

Storing tracked quantities

For a network of N targets, could discuss “ $N \times N$ ” connections

SC matrix: matrix of *structural* properties, such as average FA in a WMC connecting two targets (off-diagonal) or WMC through single target (on-diagonal)

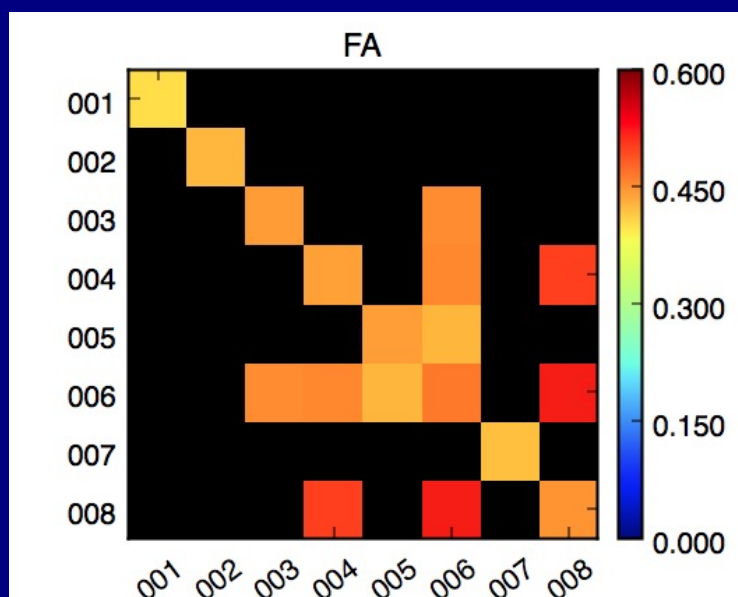

Storing tracked quantities

For a network of N targets, could discuss “ $N \times N$ ” connections

SC matrix: matrix of *structural* properties, such as average FA in a WMC connecting two targets (off-diagonal) or WMC through single target (on-diagonal)

Consider similarities with **FC matrix:** matrix of *functional* properties, such as average correlation between each pair of targets (\rightarrow value stored in each off-diagonal element)

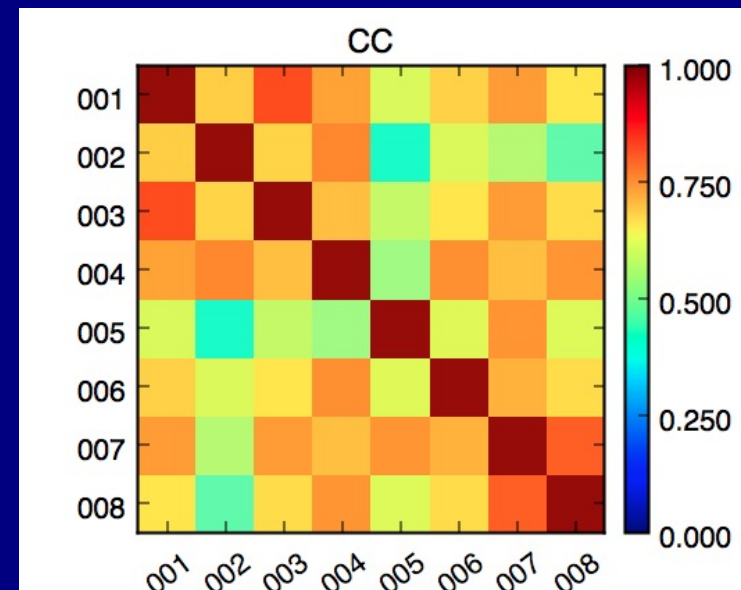
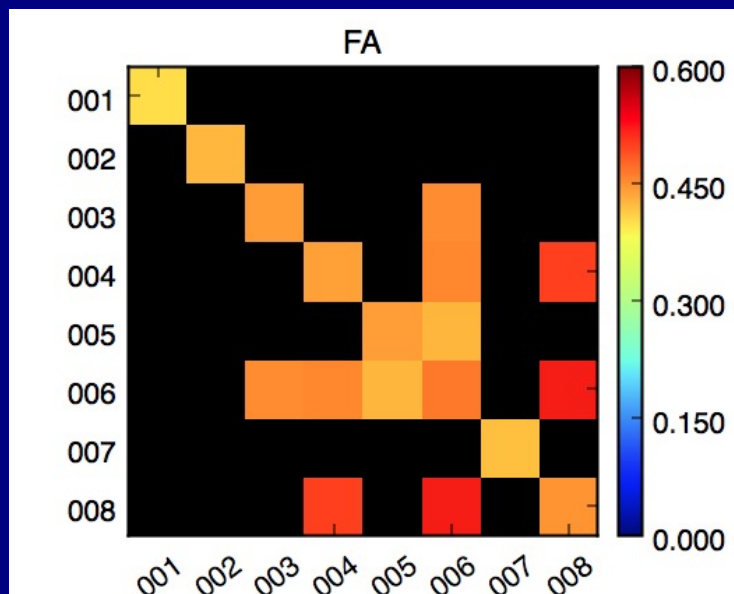

Function + structure:
motivating example

Structure + Function

Simple example:

GM ROIs
network:

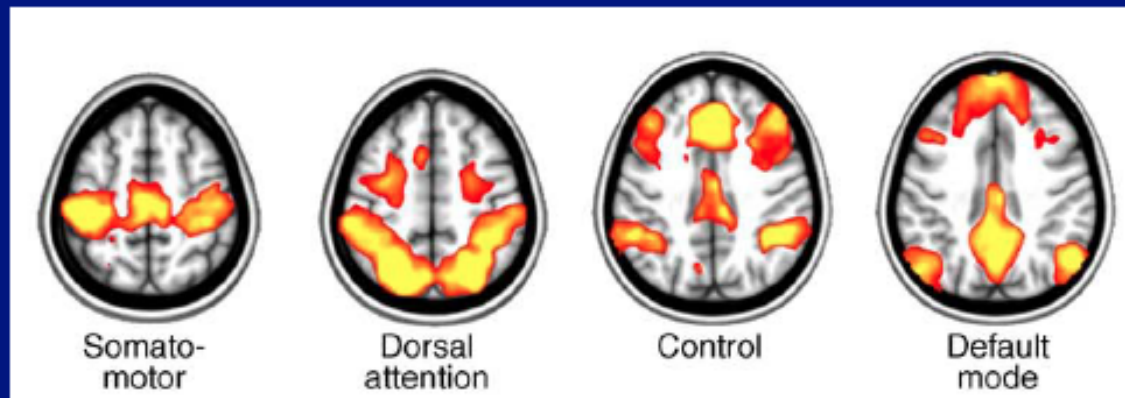

Raichle (2010, TICS)

Structure + Function

Simple example:

GM ROIs
network:

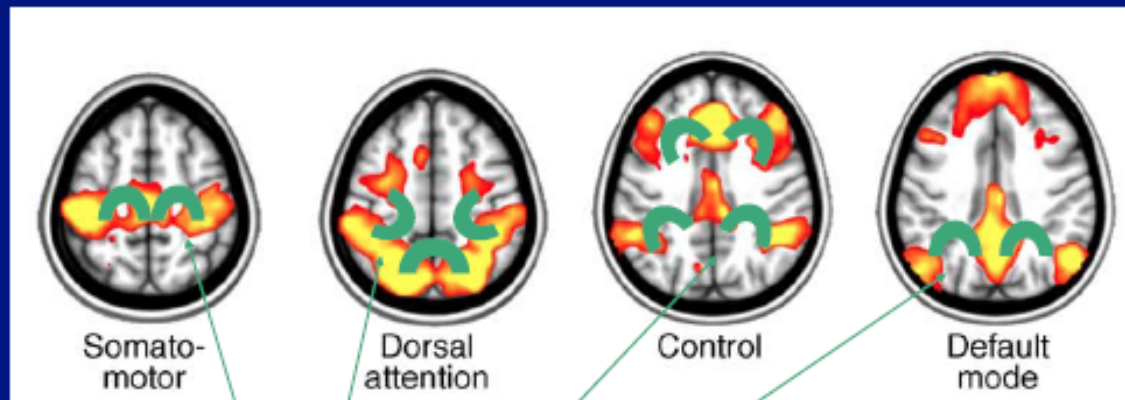

Raichle (2010, TICS)

Associated WM ROIs

Structure + Function

Simple example:

GM ROIs
network:

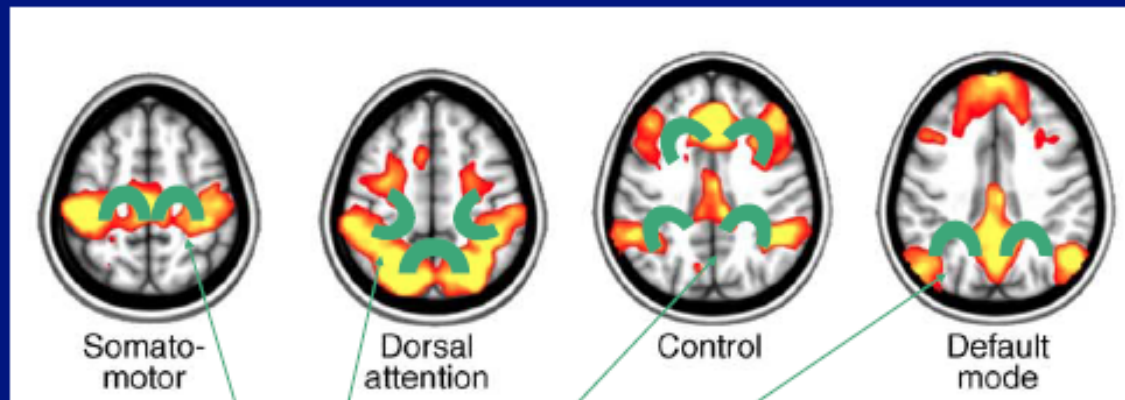

Raichle (2010, TICS)

Associated WM ROIs

Our goal for tractography->

*estimate likely/probable locations of WM associated with GM,
and relate ROI quantities with functional/GM properties*

Combining FC and SC

- + How to combine *quantitatively*?
 - fMRI has measures of functional **connectivity** and **'strength'** (e.g., correlation, network parameters)

Combining FC and SC

- + How to combine *quantitatively*?
 - fMRI has measures of functional connectivity and 'strength' (e.g., correlation, network parameters)
 - DTI tracking between GM ROIs-- we can have 'structural connectivity' strength, e.g., in terms of # of fibers?
 - > will discuss more, but think this is *not* good road to be on

Combining FC and SC

- + How to combine *quantitatively*?
 - fMRI has measures of functional connectivity and 'strength' (e.g., correlation, network parameters)
 - DTI tracking between GM ROIs-- we can have 'structural connectivity' strength, e.g., in terms of # of fibers?
 - > will discuss more, but think this is *not* good road to be on
 - how about:
 - find *likely areas* where WM is connecting GM regions, and *separately quantify* properties in those regions (FA, MD, proton density from structural images...)

Combining FC and SC

- + How to combine *quantitatively*?
 - fMRI has measures of functional connectivity and 'strength' (e.g., correlation, network parameters)
 - DTI tracking between GM ROIs-- we can have 'structural connectivity' strength, e.g., in terms of # of fibers?
 - > will discuss more, but think this is *not* good road to be on
 - how about:
 - find likely areas where WM is connecting GM regions, and *separately* quantify properties in those regions (FA, MD, proton density from structural images...)

→ FC+SC provides sets of complementary quantities to describe a network, and can be further combined with behavioral/other measures (statistical modeling).

Cinematic side note:

La Belle et la Bête of tractography



Known Challenges for Tracking

- + Axon diameters are of order a few micrometers
- + MRI voxel size is of order millimeters

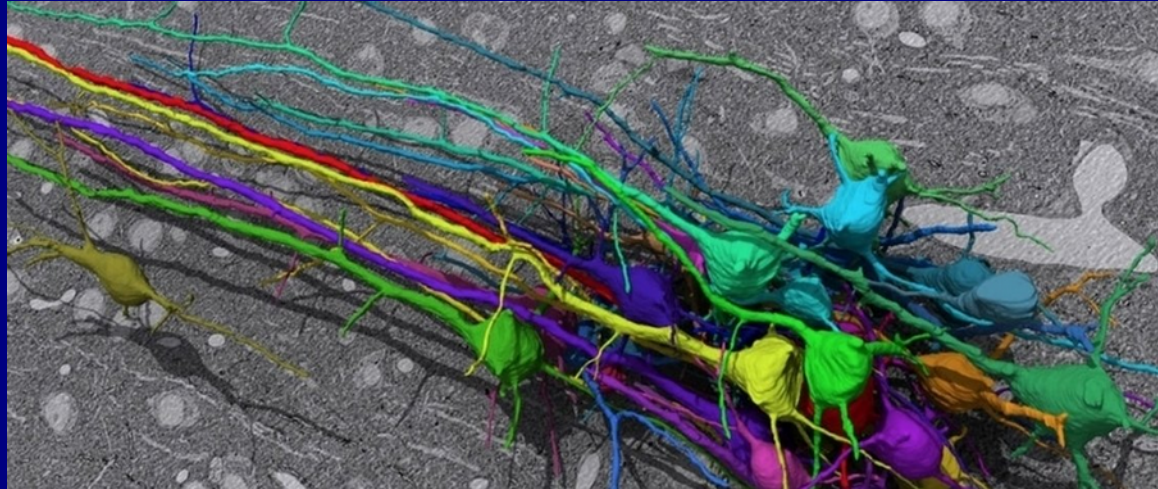
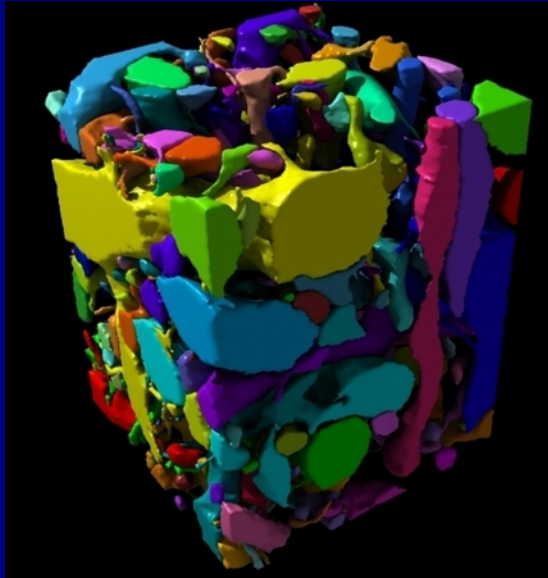

(images of Eyewire data via NPR website)

Known Challenges for Tracking



- + Axon diameters are of order a few micrometers
- + MRI voxel size is of order millimeters

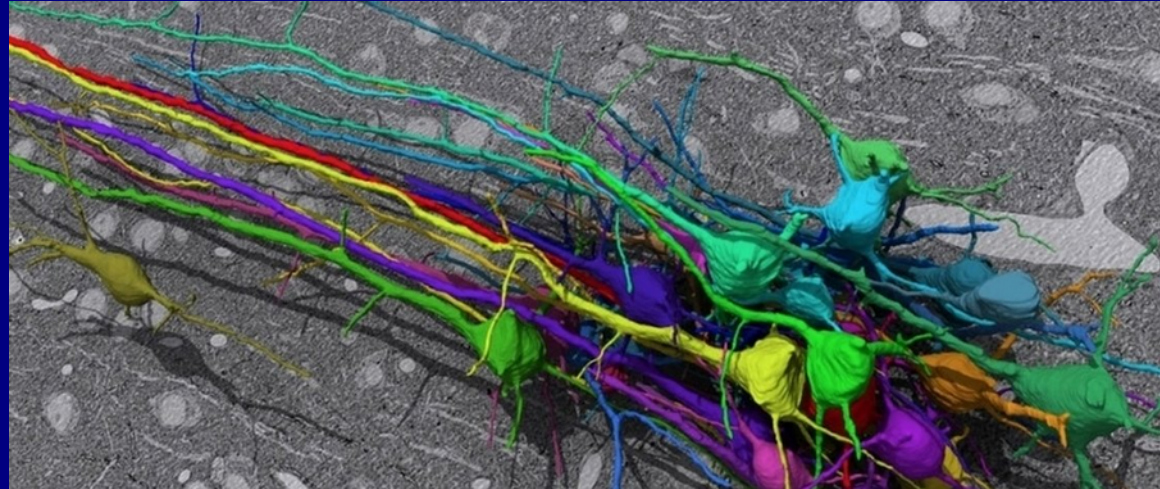
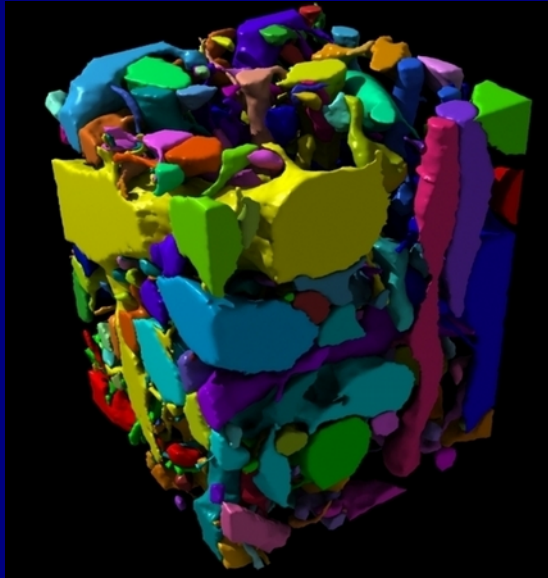

(images of Eyewire data via NPR website)

- + WM regions are tightly packed, with many connections and potentially complicated sub-voxel scale structure

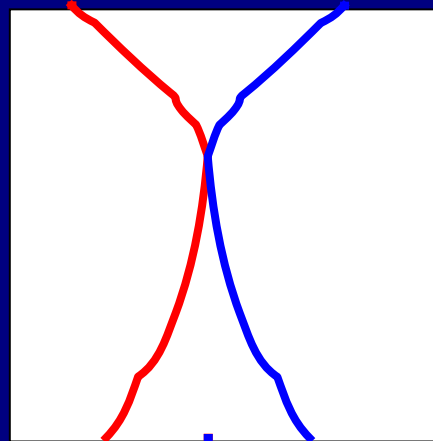
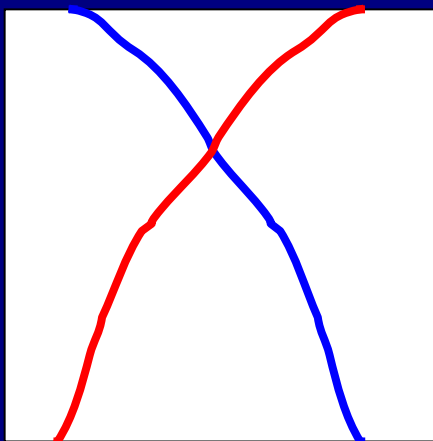

Crossing/kissing fibers can:

- Lower FA (stop tracking)
- Redirect (or *not*) tracking incorrectly.

Achievements of Tracking



- + Reproduction of many known pathways
- + In vivo vs post-mortem information



(Bammer et al., 2003)

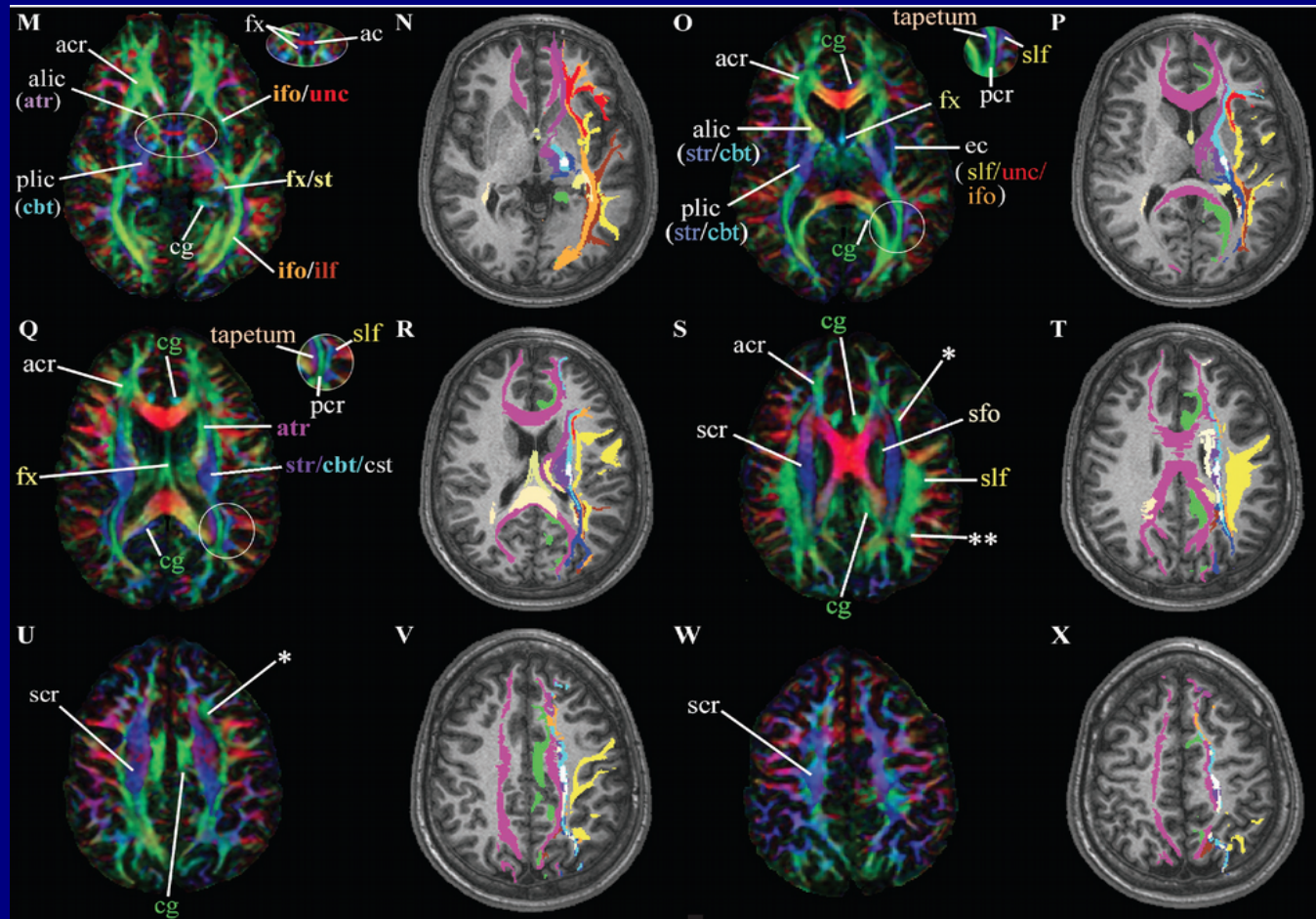

(Wakana et al., 2004)

Light at the end of the tunnel?



Tractography seems useful and logically consistent as follows:

- 1) GM ROIs *are* connected by WM skeleton.
- 2) We can use tracking to estimate and highlight WM *likely* to be associated with GM ROIs.
- 3) One can then use DTI parameters in the tracked 'WM ROIs' for quantitative comparisons (or use ROIs as masks for other data).
- 4) Tractography can parcellate the WM skeleton based on the subject's own data.
- 5) Avoid interpreting reconstructed tracks to represent literal, underlying fibers.

SUMMARY

- + Tractography can parcellate a subject's WM skeleton from their own data (don't need templates/nonlinear warping).
- + We use tracking to highlight segments of WM that are *most likely* associated with target regions of interest.
- + Tracking is used to define WMCs, from which we can calculate average (or other) types of structural properties.
- + We can investigate structural properties of *networks* of target ROIs, and complement functional studies.
- + The main quantity of interest is a (symmetric) matrix of properties per WMC, per subject (-> use in group analysis and stats modeling is discussed later).

